

JX12J Horizontal Order Picker

Characteristics

- 1.AC drive system, electronic powered steering and vertical reducer make the truck easy to operate and have excellence performance.
- 2.The power unit with low noise and low fault rate has reliable performance and high efficiency.
- 3.Battery side pulling way supports continuous operation and makes maintenance convenient.
- 4.Standard configuration of emergency stop switch and emergency reverse device ensure truck safety.
- 5.Lifting limit function ensure truck safety and reliability.
- 6.Inching buttons on two sides of truck control inching movement of the truck.



Manufacturer's Data and Design Characteristics

Characteristics			
1.1	Manufacturer		HELI
1.2	Model		JX12J
1.3	Operator type		Stand On
1.4	Rated capacity	Q (kg)	1200
1.5	Lift height	h3 (mm)	700
1.6	Service weight with battery	kg	1070
1.7	Load centre	c (mm)	600
1.8	Axle centre to fork face	x (mm)	675
1.9	Wheel base	y (mm)	1875
1.10	Controller		CURTIS
Wheels			
2.1	Tyre type		Polyurethane
2.2	Tyre size, Driving wheel	Φ×w(mm)	Φ250×75
2.3	Tyre size, Loading wheel	Φ×w(mm)	Φ80×70
2.4	Additional wheels (dimensions)	Φ×w(mm)	Φ115×55
2.5	Wheels, number front/rear (x= driven)		1x+2/4
2.6	Track width, rear, loading side	b11 (mm)	390/515
Dimensions			
3.1	Overall length	l1 (mm)	2551
3.2	Length to fork face	l2 (mm)	1400
3.3	Overall width	b1 (mm)	808
3.4	Overall height	h1 (mm)	1253
3.5	Fork dimensions	s/e/l (mm)	60/180/1150
3.6	Width of forks	b5 (mm)	695/570
3.7	Lowered height	h13 (mm)	86
3.8	Min.Ground clearance	m2 (mm)	26
3.9	height drawbar in driving position	h14 (mm)	1090
3.10	Aisle width with pallet 1000 x 1200 across forks	Ast (mm)	2960
3.11	Aisle width with pallet 800 x 1200 along forks	Ast (mm)	2940
3.12	Min.Turning radius	Wa (mm)	2076
Performance			
4.1	Travel speed,with/without load	(km/h)	5.2/5.5
4.2	Lifting speed, with/without load	(mm/s)	95/160
4.3	Lowering speed, with/without load	(mm/s)	130/120
4.4	Max. gradeability laden/unladen	(%)	3/6
4.5	Service brake type		Electromagnetic brake
Drive and Battery			
5.1	Drive motor,output S2 60 min.	(kW)	1.5 (AC)
5.2	Lift motor rating at S3 15%	(kW)	2.2 (DC)
5.3	Battery according to DIN 43531/35/36 A,B,C,no		no
5.4	Battery voltage/rated capacity	(V/Ah)	24/360
5.5	Battery weight (± 5%)	(kg)	310
Others			
6.1	Type of drive control		AC
6.2	Sound pressure level at driver 's ear	(dB(A))	≤75
6.3	Steering type		Electronic steering

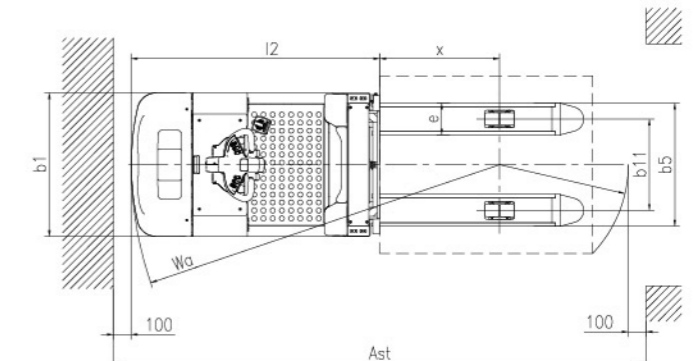
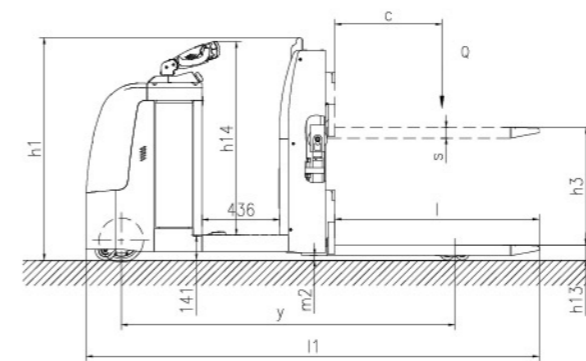

ANHUI HELI CO., LTD.

Add / No.668, FangXing Road, Hefei, China
Fax / +86-551-63639966

Tel / +86-551-63639068(America); 63639258(Europe);
63639358(Asia); 63662105(Africa & Middle East);
63639530(Key Accounts Division); 63662105(Wheel loader)