

### CDD10RD-S CDD12RD-S Electric Stacker with Initial Lift

#### Characteristics

- Compact design with a very small turning radius offers a range of application option in very confined space.
- Mast with excellent visibility is assembled on the truck.
- The truck adopts 4- points support structure, side positioned tiller and low center of gravity design which featuring excellent stability.
- Double pallet design: two pallet can be handled at one time; initial lift of load leg increases ground clearance to facilitate traffic ability on ramps, dock levelers and bridge.
- Vertical driving wheel offers small turning radius; dustproof waterproof motor is easy for maintenance.
- High efficient electromagnetic parking brake offers good ramp braking performance.
- Low voltage protection setting prolongs the battery life.
- Height adjustable balance wheel ensures the drive wheel life.



Mast with excellent visibility for wide view of the forks.



Compact design With very small turning radius, offer a range of application option in very confined space.



With double decker ,mast lift 1000kgs and support arm lift 1000kgs, total load is 1000kgs if use double pallet.

#### Manufacturer's Data and Technical Characteristics

Characteristics			HELI	
			CDD10RD-S	CDD12RD-S
1.01	Manufacturer		HELI	
1.02	Model		CDD10RD-S	CDD12RD-S
1.03	Mast type		2-stage mast	
1.04	Load capacity	Q kg	1000	1200
1.05	Load center distance	C mm	600	
1.06	Driving mode		Walkie	
1.07	Front overhang	x mm	812	
1.08	Wheel base	Y mm	1272	
Tyre				
2.01	tyre type		Polyurethane	
2.02	Wheels number,Front/rear(X=driven wheels)		1x+1/4	
2.03	Track Width,front	b10 mm	523	
2.04	Track Width,rear	b11 mm	390	
2.04	Wheel size, front		ø195x70	
2.05	Wheel size, rear		ø80x70	
2.06	Wheel size, additional		ø150x60	
Dimension				
3.01	Lift height	h3 mm	1600/1950	
3.02	Height, mast extended	h4 mm	2060/2410	
3.03	Height, mast lowered	h1 mm	2050/2400	
3.04	height,lowered	h13 mm	90	
3.05	Initial lift	h5 mm	120	
3.06	Fork size	s/e/l mm	60/180/1070(1150)	
3.07	Overall length	l1 mm	1690/1770	
3.08	Length to face of forks	l2 mm	619	
3.09	Overall width	b1 mm	800	
3.10	Width across forks	b5 mm	570	
3.11	Turning radius	Wa mm	1450	
3.12	Aisle width with pallet 800Wx1200L,clearance 200	Ast mm	2224	
3.13	ground clearance	m2 mm	17~137	
Performance				
4.01	Travelling speed,laden/unladen	km/h	4.5/5	
4.02	Lifting speed,laden/unladen	m/s	0.11/0.14	
4.03	Lowering speed,laden/unladen	m/s	0.12/0.12	
4.04	Gradeability,laden/unladen	%	6/15	
Electrical configuration				
5.01	Drive moter power	kw	0.65	
5.02	Lifting moter power	kw	2.2	
5.03	Battery voltage	V	24	
5.04	Battery capacity	Ah	105(125)	
5.05	Battery dimensions l/w/h	mm	329x172x214	
5.06	Controller		CURTIS	
5.07	Brake		Electromagnetic	
Weight				
6.01	Total weight(with battery)	kg	640	685
6.02	Battery weight	kg	60.8	

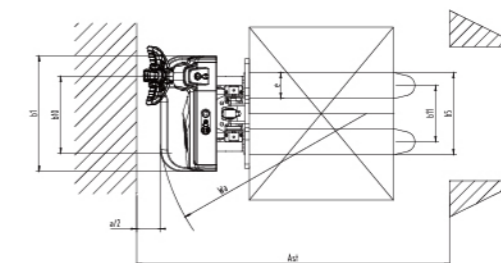
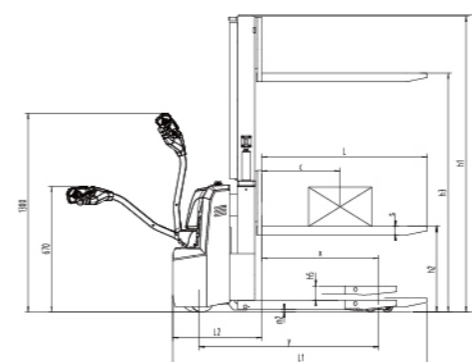

**ANHUI HELI CO., LTD.**

Add / No.668, FangXing Road, Hefei, China  
Fax / +86-551-63639966

Tel / +86-551-63639068(America); 63639258(Europe);  
63639358(Asia); 63662105(Africa & Middle East);  
63639530(Key Accounts Division); 63662105(Wheel loader)