

# HELI

## CBD15J/18J/20J-Li3 Lithium Battery Powered Pallet Truck

### Characteristics:

- The whole vehicle is simple, dexterous, reliable and easy to operate. It has a compact structure, small turning radius and it's suitable for operation in a narrow space.
- The vehicle is compact and reliable, equipped with a full protective metal housing.
- Portable lithium electric bag, easy to open the cover and replace the battery.
- Standard equipped with emergency stop switch and emergency reverse device to ensure safe use.
- With power off brake function, when release handle or press bottom, the vehicle immediately power off brake.
- The dual protection of electromagnetic braking and motor braking is used to ensure the safety of driving.



## CBD15J/18J/20J-Li3

### Manufacturer's Data and Design Characteristics

Characteristics		HELI							
1.01	Manufacturer	HELI							
1.02	Model	CBD15J-Li3		CBD18J-Li3		CBD20J-Li3			
1.03	Power unit	Electric		Electric		Electric			
1.04	Operation	Pedestrian		Pedestrian		Pedestrian			
1.05	Rated traction weight	Q (t)	1.5		1.8		2.0		
1.06	Load centre	c (mm)	600		600		600		
1.07	Axle centre to fork face	x (mm)	944		944		944		
1.08	Wheel base	y (mm)	1190		1190		1190		
Weights									
2.01	Service weight with battery	kg	138		148		150		
Wheels/Tyres									
3.01	Wheels type		Polyurethane		Polyurethane		Polyurethane		
3.02	Driving wheel size	Φ×w(mm)	Φ210×70		Φ210×70		Φ210×70		
3.03	Bearing wheel size	Φ×w(mm)	Φ80×60		Φ80×60		Φ80×60		
3.04	Wheels, number front/rear (x = driven)		1x/4		1x/4		1x/4		
3.05	Track width	b11 (mm)	400/535		400/535		400/535		
Dimensions									
4.01	Lift	h3 (mm)	200		200		200		
4.02	Overall height(With handle)	h14 (mm)	725/1145		725/1145		725/1145		
4.03	Lowered height	h13 (mm)	85		85		85		
4.04	Overall length	l1 (mm)	1550		1550		1550		
4.05	Length to fork face	l2 (mm)	400		400		400		
4.06	Overall width	b1/ b2 (mm)	550/685		550/685		550/685		
4.07	Fork dimensions	s/e/l (mm)	50/150/1150		50/150/1150		50/150/1150		
4.08	Width of forks	b5 (mm)	550/685		550/685		550/685		
4.09	Min.Ground clearance	m2 (mm)	35		35		35		
4.10	Aisle width with pallet 1000 x 1200 across forks	Ast (mm)	1750		1750		1750		
4.11	Aisle width with pallet 800 x 1200 along forks	Ast (mm)	1800		1800		1800		
4.12	Min.Turning radius	Wa (mm)	1345		1345		1345		
Performance									
5.01	Travel speed,laden/unladen	(km/h)	4.2/4.5		4.2/4.5		4.2/4.5		
5.02	Maximum climbing ability, with/without load	(%)	5/10		5/10		5/10		
5.03	Service brake		Electromagnetic brake		Electromagnetic brake		Electromagnetic brake		
Drive									
6.01	Drive motor, 60 minute rating	(kW)	0.75		0.75		0.75		
6.02	Lift motor rating at S3 15%	(kW)	0.8		0.8		0.8		
6.03	Battery according to DIN 43531/35/36 A,B,C,no		no		no		no		
6.04	Battery voltage/rated capacity	(V/Ah)	24/20	24/30	24/40	48/15	48/20	48/15	48/20
6.05	Battery weight (± 5%)	(kg)	5.5	7	8.2	7	8.2	7	8.2
Others									
7.01	Type of drive control		DC		DC		DC		
7.02	Noise level at operator's ear	(dB(A))	≤70		≤70		≤70		
7.03	Steering type		Mechanical steering		Mechanical steering		Mechanical steering		
7.04	Controller brand		Curtis		Curtis		Curtis		

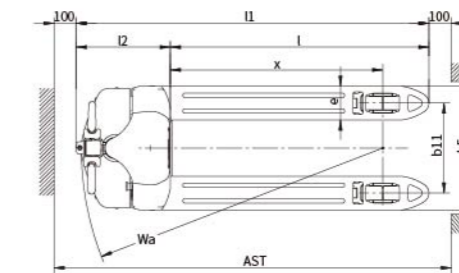
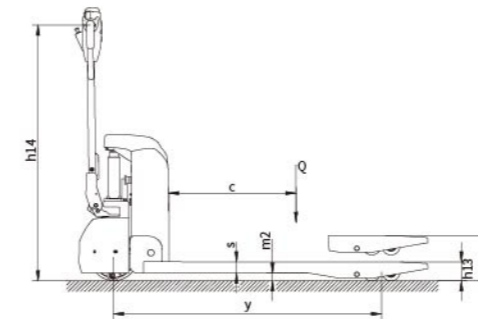

Design&Print:Fokeli Printing 20220321



**ANHUI HELI CO., LTD.**

Add / No.668, FangXing Road, Hefei, China

Fax / +86-551-63639966

Tel / +86-551-63639068(America); 63639258(Europe); 63639358(Asia);  
63662105(Africa & Middle East); 63639530(Overseas Marketing)

\* Our products are subject to improvements and changes without notice.



LinkedIn



YouTube



Facebook